

article.<sup>12</sup> Applying the formula derived there  $r_u = R_I^4/R_{II}^3$  and introducing the values of  $R_I = ROxN$  and  $R_{II} = ROx_2S_2O_6$  from the tables, we find the values of  $r_u$  corresponding to the concentrations  $c$  as follows,

$c$ .....	0.01	0.02	0.05	0.10
$r_u$ .....	1.019	0.997	0.998	1.013

that is to say, values very near unity. As far as these experiments are concerned, the salting-out effects of the two solvents are then very nearly identical.

### Summary

1. The principle of the specific interaction of ions is presented in the form of a simple equation and a diagram.

2. The individualities of the thermodynamic properties of salts vary linearly with their concentration when the total concentration is kept constant. On the basis of this law several of the results obtained by means of the principle of the specific interaction may be derived.

3. Thermodynamic and experimental evidence to prove the invalidity of the principle of the independent activity coefficients has been adduced.

4. Solubility measurements embracing a series of cobaltic ammonia salts in solutions of sodium sulfate and sodium chloride have been carried out. The results were found in full agreement with the principle of the specific interaction.

COPENHAGEN, DENMARK

---

[CONTRIBUTION FROM THE LABORATORY OF PHYSICAL CHEMISTRY OF THE UNIVERSITY OF WISCONSIN]

## DETERMINATION OF SIZE AND DISTRIBUTION OF SIZE OF PARTICLE BY CENTRIFUGAL METHODS

BY THE SVEDBERG AND J. BURTON NICHOLS

RECEIVED SEPTEMBER 14, 1923

In the determination of size and distribution of size of particle through gravity sedimentation by Odén's method<sup>1</sup> one is limited to relatively coarsely grained sols of about 100  $\mu\mu$  radius or larger. Since this is due to the extremely slow rate of settling, if the effect of gravity be increased sols of true colloidal size might thus be determined. To this end we have employed centrifugal force, and since direct weighing becomes impracticable here we designed a special centrifuge so constructed that the sol may be observed as it is precipitated. Then for a uniform sol, size of particle may be determined by measuring the rate of movement outward of the boundary of the particles and applying a modified form of Stokes' law.

<sup>12</sup> Ref. 1, p. 885.

<sup>1</sup> Odén, *Bull. Geol. Inst. Upsala*, **16**, 15 (1918).

With the centrifuge the acceleration of the particle is no longer constant as in the case of gravity sedimentation but varies with the distance from the center.

Let  $a$  be the distance from the axis of rotation to the meniscus of the sol in the centrifuge tube. Then let  $x$  be the distance the boundary of the particles has moved in a given time  $t$ . Now consider the forces acting on a particle at the point  $x$ . The frictional force which tends to cause it to resist movement is  $6\pi\eta r(dx/dt)$  where  $\eta$  is the viscosity of the liquid,  $r$  the radius of the particle considered to be a sphere, and  $dx/dt$  its velocity. But the centrifugal force applied to cause movement is  $4/3 \pi r^3(d_p - d_l)w^2(x + a)$ ,  $(d_p - d_l)$  being the difference in density between the particles and dispersion medium,  $w$  the angular velocity, and  $(x + a)$  the distance from the axis of rotation to the particle.

Equating and rearranging for integration

$$\int_0^t r^2 dt = \int_0^x \frac{9\eta}{2(d_p - d_l)w^2} \frac{dx}{x + a}$$

$$r^2 t = \frac{9\eta}{2(d_p - d_l)w^2} \ln \left( \frac{x + a}{a} \right)$$

$$r = \sqrt{\frac{9\eta \ln \left( \frac{x + a}{a} \right)}{2(d_p - d_l)w^2 t}} \quad (1)$$

Therefore, by measuring the distance  $x$  which the boundary of the sol has moved out in a time  $t$ , and obtaining the speed of the centrifuge it is possible to determine  $r$ .

Fig. 1 shows the centrifuge devised. The rotor A is directly connected at B to a Dumore special 20,000 r.p.m. motor C suspended in the heavy metal casing D and supported by a pivot bearing E. The machine is mounted on a large wooden base F, laminated to prevent warping, and several thicknesses of linoleum are glued on the top and bottom to absorb vibration.

The rotor is enclosed in a square metal box G for the purpose of protecting the tube from air currents and resulting temperature differences. Air may be blown through the box also in order to obtain constant temperature. The top is made removable so that the rotor may be adjusted when necessary.

The rotor consists of the central head H, horizontally cored I, to which are screwed the two arms J, also cored to correspond to the core of the head. These arms are closed at the outer end by screw caps K to provide a means for changing the tubes I contained. In order to obtain vertical or horizontal illumination of the tubes, the arms are slotted M, top and bottom and on both sides.

The tubes used I, one for each arm, are made of a good resistance glass tubing such as Pyrex or Jena, sealed off smoothly at the outer end and closed at the inner end by paraffined corks. To prevent too much strain on the rounded portion a plastic substance is filled in the space between the tube and the cap K.

A thin metal disk N, of slightly greater diameter than the length of the rotor, attached to the head just below the arms, is slotted at O directly under the vertical slots in the arms and is fixed in position so that no relative motion of arms and disc will take place. This slotted disk therefore allows light to travel up through the box only when an arm is directly over the narrow beam of light employed for illumination.

Underneath the box is mounted a narrow plane mirror P for directing a uniform beam of light vertically through a slot Q in the bottom of the box, of the same length as the slots in the arms, so that every time an arm passes over this slot a beam of light travels up through the slots in the arm and through a corresponding slot in the top of the box, where the image of the contents of the tube may be observed or photographed. There is also a slot in the side of the box at such a height that light reflected from the contents of the tubes also may be viewed or photographed.

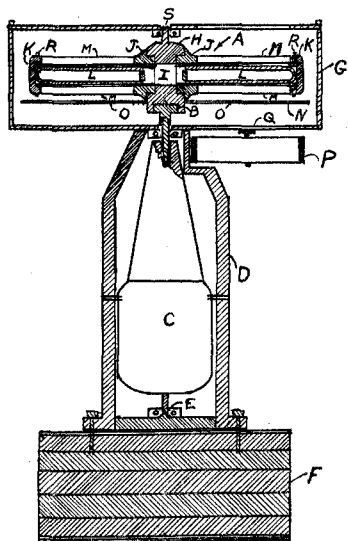

Fig. 1

just below the point of support, such arrangement giving maximum sensitivity. Then the end of each arm was threaded and adjustable rings R

The most difficult problem to solve was to provide a good means of balancing the rotor. This is essential, for when it is not in exact balance the vibrations tend to mix the colloid and vitiate the effect of the force applied. Several different methods were employed but none was sensitive enough. However, the desired sensitivity was finally obtained by inserting a hardened steel peg on each side of the head, in order to furnish a means of support for the rotor on knife edges. These rods are so situated that the center of gravity of the rotor lies

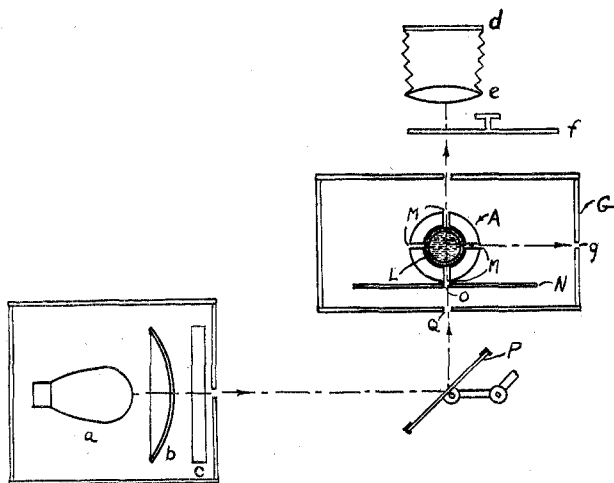

Fig. 2

gave us the means for varying the movement of the arms so that they would come to rest in a horizontal position.

Fig. 2 gives a diagrammatic representation of the apparatus and the path of the beam of light up through the sol in the centrifuge tube to the photographic plate. In this case the section of the centrifuge box is at right angles to the view shown in Fig. 1.

The source of light is a concentrated filament electric light bulb *a*; *b* is a lens of white glass to make the light beam of uniform color and intensity; *c* is a water cell for cooling the beam. This system is entirely enclosed in a large, asbestos-lined box to shut out stray light from the camera lens. The light then travels through a slot in the side of the box to the narrow plane mirror *P* mentioned before, which reflects it up into the centrifuge box through the slot *Q*. Now if the arm is directly over this slot the beam of light can continue up through the slot *O* in the disc screen and through the slots *M* in the arms and out at the top slot in the box where the image of the illuminated tube containing the sol is thrown on the photographic plate *d*, by the large lens *e*; *f* is a sector wheel rotated at a constant rate by a small motor so as to give a known length of time of exposure to the plate.

If it is desired to photograph the reflected light from the colloid rather than the transmitted light, the camera arrangement may be changed to a horizontal position in front of the slot *g*. In this arrangement another light system of equal intensity to that shown is introduced so that both the bottom and the top side of the tube can be equally lighted.

Speed regulation is provided for by inserting a variable resistance in the field circuit of the motor. In this way any desired speed may be obtained. Speed of the machine is determined by inserting a speed counter or indicating tachometer at *S*, the top of the axis of rotation (Fig. 1).

### Uniform Sols

The first material studied was two gold hydrosols prepared by means of Zsigmondy's nuclear method.

Equal amounts of one of the sols were sealed in centrifuge tubes and placed in the rotor of the machine. The centrifuge was started, the resistance adjusted to give the desired speed and the time of starting noted when the centrifuge had come up to speed. After a certain length of time the distance the boundary had moved was measured either directly by means of a centimeter scale on a glass slide or else by photographing the tube and measuring the distance from the meniscus of the sol to the boundary of the particles. The latter procedure is necessary when the boundary is not sharp. In order to get the correct point the gradual increase in density of the plate in this region was measured with a König Martin photometer and the point of medium density was considered to be the edge of the boundary; then by taking another photograph later and determining

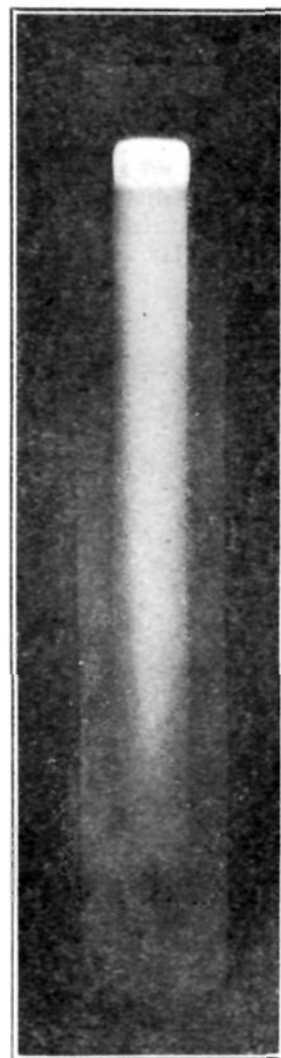

Fig. 3

the point on the picture corresponding to the same density the true distance moved in the given time interval could be determined.

Fig. 3 indicates the appearance of the photograph obtained. The particular photograph shown is of gold sol No. 2 at the end of 30 minutes of centrifuging.

In order to verify the values obtained from the runs with the centrifuge, the sols were determined directly by means of the ultramicroscope.

TABLE I  
DATA ON GOLD HYDROSOL NUMBER 1

$$r = \sqrt{\frac{9\eta \ln \frac{x+a}{a}}{2(d_p-d_i)w^2t}}$$

where  $a$  = distance from axis of rotation to meniscus of sol, 2.7 cm.;  $t$  = time of centrifuging in minutes;  $x$  = distance sedimented in cm.;  $r$  = radius in  $\mu\mu$ ;  $\eta$  = viscosity, 0.01;  $w$  = angular velocity,  $60\pi$ ;  $d_p-d_i$  = difference in density, 18.32.

$t$ Min.	$x$ Cm.	$r$ $\mu\mu$	$r$ (from ultramicroscope determination) $\mu\mu$
10	0.15	24.1	
20	.28	21.1	
30	.42	20.9	21.8

TABLE II  
DATA ON GOLD HYDROSOL NUMBER 2  
 $a = 2.0$  cm.;  $\eta = 0.01$ ;  $d_p-d_i = 18.32$ ;  $w = 58\pi$

$t$ Min.	$x$ Cm.	$r$ $\mu\mu$	$r$ (from ultramicroscope determination) $\mu\mu$
15	0.3	34.0	
30	.7	35.1	
47	.9	32.6	33.5

In each case, considering the last value obtained with the centrifuge as the best, the results by the two methods are seen to be in very close agreement.

A sample of colloidal barium sulfate was next studied. This was made by the interaction of 0.1  $N$  barium thiocyanate with 0.1  $N$  ammonium sulfate, using potassium citrate as a protective agent.

TABLE III  
BARIUM SULFATE  
 $a = 2.4$  cm.;  $\eta = 0.01$ ;  $w = 31\pi$ ;  $d_p-d_i = 3.4$

$t$ Min.	$x_1$ Cm.	$x_2$ Cm.	$r_1$ $\mu\mu$	$r_2$ $\mu\mu$	$r$ (from ultramicroscope determination) $\mu\mu$
60	0.3	1.4	67.7	142.2	
105	.7	5.5	75.3	154.5	
135	.9	6.6	74.0	151.0	93.3

With the barium sulfate used a very sharp boundary was obtained representing the larger size of particle, probably indicating a steep maximum at this point, and a fainter boundary representing the minimum size of particle present. As might be expected with two such very differently sized particles, the ultramicroscopic determination representing the average size of particle gives us very little information here. In addition, the barium sulfate particles scatter very little light, so the counts are difficult to make with the ultramicroscope.

The next material studied was a sample of Putnam clay prepared by Professor Bradfield of the University of Missouri. This contained a fairly narrow range of size of particle, since it represented that fraction obtained on passing the clay through a Sharples centrifuge at a speed of 30,000 r.p.m., collecting a 3-minute fraction and then passing this fraction through again and collecting the particles thrown out in three minutes.

The following results were obtained.

TABLE IV

## CLAY

$$a = 2.5 \text{ cm.}; \eta = 0.01; w = 58\pi; d_p - d_i = 1.6$$

<i>t</i> Min.	$x_1$ Cm.	$r_1$ $\mu\mu$	$r$ (from ultramicroscope determination) $\mu\mu$
60	0.2	43.3	
90	.3	42.1	
			49.4
135	.45	41.7	
345	1.15	39.4	

Since a slight error in measurement of the larger distance does not introduce so great an error in the results, the lower value of  $r$  obtained in the centrifuge run probably represents the minimum size of particle present. In the ultramicroscopic determination the particles were difficult to distinguish, as similar to the barium sulfate, they scatter very little light.

A sol of arsenious sulfide prepared by passing hydrogen sulfide into a solution of arsenic trioxide was also studied. As in the case of the sol of barium sulfate a double boundary appeared, the outer one being very sharp, while the inner was rather faint and indistinct.

TABLE V

## ARSENIC TRISULFIDE SOL

$$a = 2.7 \text{ cm.}; \eta = 0.01; w = 58\pi; d_p - d_i = 2.46$$

<i>t</i> Min.	$x_1$ Cm.	$x_2$ Cm.	$r_1$ $\mu\mu$	$r_2$ $\mu\mu$	$r$ (from ultramicroscope determination) $\mu\mu$
17	0.2	0.3	62.3	75.5	
					74.0
30	.4	.55	65.2	75.5	
45	.6	.8	63.9	73.7	

It should be noted that with non-spherical particles such as those of barium sulfate, arsenious sulfide, and clay the values of  $r$  determined do not represent the actual radius but the equivalent radius of a spherical particle of the material that would sediment at the same rate as the actual particle.

### Non-Uniform Sols

Since most colloidal material contains a wide range of sizes of particles, the method just described for observing the movement of the boundary can give us complete information on only a few substances or at most the smallest size of particles contained in a non-uniform sol.

Therefore the next problem is to work out the method for determining the relative amounts present of each size of particle in a sol. One of us<sup>2</sup> has already developed the theory of the method, using an approximate formula for  $r$ . The following is more exact.

In a thin layer  $dx$  of a sedimenting sol the change in concentration  $dc$  from the section at  $x$  to the section  $x + dx$  is due to particle with radius  $r$  to  $r + dr$ , the values of  $r$  being determined from the modified form of Stokes' law, Equation 1. By obtaining the change in  $c$  with  $x$ , that is  $dc/dx$ , we may determine the distribution function  $\frac{dc}{dr} = \frac{dc}{dx} \cdot \frac{dx}{dr}$ . In order to measure  $dx/dr$  let us rearrange Equation 1 to the form

$$\ln \frac{x+a}{a} = \frac{2(d_p - d_l) w^2 t r^2}{9\eta}$$

$$\text{Let } B = \sqrt{\frac{9\eta}{2(d_p - d_l) w^2 t}}$$

Substituting and differentiating,

$$\frac{dx}{x+a} = \frac{2r dr}{B^2}$$

Substituting the value of  $r$  from Equation 1 and rearranging,

$$\frac{dx}{dr} = \frac{2(x+a) \sqrt{\ln \frac{x+a}{a}}}{B}$$

$a$  being again the distance from the axis of rotation to the point  $x = 0$ . This then gives

$$\frac{dc}{dr} = \frac{2(x+a) \sqrt{\ln \frac{x+a}{a}}}{B} \frac{dc}{dx} \quad (2)$$

The following procedure is necessary in order to obtain the variation in concentration with distance  $x$  in the centrifuge tubes. First, a picture is taken of the contents of the centrifuge tube when the rotor has just come up to speed and practically no sedimentation has taken place. Then a photograph is taken on the same plate after a given length of time of running and a third photograph is taken of a wedge cell of the material. All

<sup>2</sup> Svedberg and Rinde, *THIS JOURNAL*, 45, 943 (1923).

three pictures must be given the same intensity of illumination and length of exposure.

Then by comparing the second and the third strips in a photometer, we obtain the density on the wedge cell strip corresponding to the density of the sol representing its original concentration. Beer's law may then be used to determine the concentration at each layer of the wedge cell and the values obtained put in the form of a scale parallel to the photograph strip of the wedge cell. The density of this strip is next determined throughout the whole height which gives us concentration in terms of density. However, if the material under observation contains a wide range of sizes of particles, the variation of the light absorption constant with radius must be considered, as already pointed out by one of us.<sup>2</sup>

Finally, the density of each layer of the sedimenting sol may be obtained from the photograph taken of the contents of the tube after the centrifuge had been running for some time, and when what each density represents in terms of concentration is known, the change in concentration with distance,  $dc/dx$ , may be determined for the material. Now the distribution curve may be plotted using as coordinates  $dc/dr$  and  $r$ .

Investigations on non-uniform colloids are being undertaken and will form the subject of a later paper.

### Summary

1. Stokes' law has been modified to give an exact formula for determining the radius of a particle sedimenting under centrifugal force.
2. A special type of centrifuge has been described which permits a sol to be observed or photographed while it is being precipitated.
3. This method depends on the projection of a uniform beam of light up through the tube containing the material each time the tube passes over a certain point. The rate of movement of the particles in the tube may then be observed.
4. To illustrate the method for a fairly uniformly sized colloid, results for two different gold sols, clay, barium sulfate, and arsenious sulfide have been given.
5. Another method has been discussed for determining the distribution of size of particles, depending on the variation of concentration with distance from the axis of rotation in a disperse system subjected to centrifugal force.